



PARKER RESEARCH CORP.

MODEL BAC310
AC POWER SUPPLY

BULLETIN 255-1
OCT-08

NONDESTRUCTIVE TEST METHODS, SYSTEMS, INSTRUMENTS
BOX 1406, DUNEDIN, FLORIDA, U.S.A. 34697
PHONE: (727)796-4066 FAX: (727)797-3941

INSTRUMENT DESCRIPTION: The BAC310 battery operated Inverter Power Supply is a totally portable, stand alone power source. It is designed to operate any of the Parker 115VAC, A.C. Yokes (Contour Probes).

The BAC310 operates independently from any outside power source. Power is derived from the internal 12VDC battery, which is inverted to 110VAC output through the inverter circuitry. A separate battery charger is provided for overnight charging of the battery. The entire BAC310 unit is contained within a heavy duty steel case 11-1/2"H X 7-1/2"W X 5-1/2"D and weighs only 28 pounds. The BAC310 may be used in shop or field applications (away from water) and is ideal in areas where normal AC line power is unavailable or where outside power sources may present a safety concern.

SAFETY PRECAUTIONS: The BAC310 is a high voltage (110VAC) electrical device. Care should be taken to avoid electrical shock. Read all directions and safety precautions thoroughly before using. Do not use this equipment in or near water. Avoid exposure to rain.

DO NOT attempt to operate other electrical devices from the BAC310. It is designed to power Parker and other manufacturers 115V A.C. Yokes. **Note:** The BAC310 will not operate the D.C. mode of AC/DC Yokes.

DO NOT attempt to operate other devices from the BAC310.

DO NOT attempt to operate more than one Yoke at the same time. The BAC310 is designed of operation of one instrument at a time only.

A.C. YOKE OPERATION: The BAC310 will operate the Parker B310, B300 or B100 A.C. Contour Probes (Yokes). With a fully charged battery, plug the standard plug of the Yoke into one of the output sockets. **Figure 1, Item 1.** Toggle the ON-OFF switch to the ON position. **Figure 1, Item 2.** There is nothing else to do. The Contour probes will function normally. Verify that the Probe will comply with the 10-pound weight lift test before and during use. Follow the operating instructions for the Yoke for correct and normal A.C. Yoke inspection techniques and requirements. A slight pulsing of the Probe may be felt. This is a characteristic of the inverter circuitry and has no effect on the normal operation of the Probes. The Parker B310, B300 and B100 will exceed applicable standards requirements.

BATTERY: The battery contained within the BAC310 is a sealed, lead acid type rated at 20Ah, 12VDC, **Figure 2, item 1.** The battery will provide power to operate the Parker B310, B300 or B100 for approximately two hours under normal conditions. Extended "time-on" of the Yokes will reduce this time. When battery level becomes too low for operation, the unit will shut down. The battery must then be recharged (overnight) or replaced by the optional BAC60-60 battery pack.



FIG. 1

BATTERY CHARGING: When it becomes necessary to recharge the battery, the BC310 battery charger is provided; **Figure 2, Item 2.** This is a trickle type charger rated at 12VDC, 1.0 or 2.0 amps allowing for overnight charging.

Open the BAC310 case cover and remove the charger. Disconnect the inverter plug from the battery pack connector. Plug the battery charger connector into the connector of the battery. These will only connect one way. The exposed metal pin is the Ground. Plug the battery charger into a standard 115V outlet.

CAUTION: The BAC310 cover should never be closed during battery charging. Always charge the battery in a well ventilated area. Always disconnect the AC power cord before connecting or disconnecting the charger from the battery. **ALWAYS WEAR EYE PROTECTION WHEN CHARGING OR REPLACING THE BATTERY.**

BATTERY REPLACEMENT: The battery pack contained within the BAC310 may be changed to extend operating times. To replace the battery pack, disconnect the inverter plug from the battery socket. Remove the two battery bracket screws located on the rear of the steel case. **Figure 2, Item 3.** Lift the entire battery and bracket assembly straight up and out of the case with one finger placed through bracket hole. **Figure 2, Item 4.** Replace with the optional BAC60-60 replacement battery pack. (Be sure it is fully charged). Lower the entire battery pack assembly into the case. Align the holes of the battery bracket screws. Replace and retighten the screws. Plug the inverter plug into the battery pack socket.

BATTERY DISPOSAL: Always dispose of batteries according to the requirements of local ordinances. Follow all cautions on the battery. **ALWAYS WEAR EYE PROTECTION WHEN WORKING WITH THE BATTERY.**

FUSE: The BAC310 battery is fused with an in line 25A fuse. **Figure 2, Item 5.** In the event the units fails to function, check the fuse and replace if necessary.

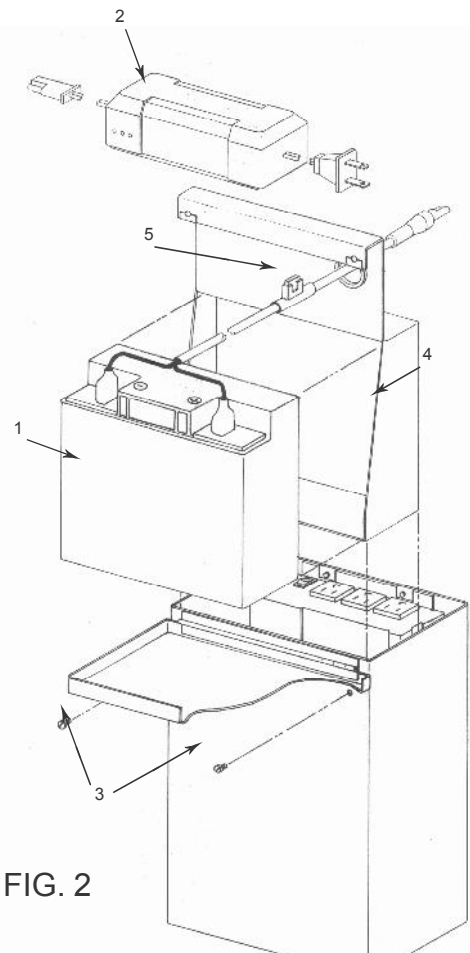

FIG. 2

PARKER RESEARCH 90 DAY WARRANTY

The BAC310 is warranted against malfunction due to defective material and workmanship. The warranty shall cover repair or replacement of the BAC310 at no charge (less incoming freight charges) for a period of ninety (90) days from the date of purchase. Warranty will not apply to units that have been altered or to those units that have been used improperly. Warranty will not cover damage to other devices that have been plugged into the BAC310.

In the event of malfunction, return the unit (prepaid) to the factory. Repair or replacement of the defective unit will be made at the discretion of Parker Research Corporation. The repaired or replacement unit will be returned to the original customer prepaid. **NOTE:** Remove the battery before returning the BAC310 for repair.

The obligation of Parker Research Corporation is limited to the repair or replacement of the defective unit. No other obligation is expressed or implied. Parker Research Corp. assumes no liability from any claim arising from the use of this equipment.

CAUTION: Proper training of operating personnel to required inspection techniques, specifications and safety requirements is necessary for the safe use of this equipment and is the obligation of the user. Follow operating instructions and safety precautions contained herein.

ALWAYS WEAR EYE PROTECTION WHEN USING THE EQUIPMENT.

SHIP TO:

**REPAIR DEPT.
PARKER RESEARCH CORP.
2642 ENTERPRISE ROAD WEST
CLEARWATER, FL 33763**